



MG 3A MG 3A-MST12¹⁾

Montagegelenk mit 3 Achsen
Mounting hinge with 3 axes
Articulation de montage avec 3 axes
Articulación de montaje con 3 ejes

- 1) für Befestigung an 12 mm Montagestangen
- 1) for fixing at mounting rods 12 mm
- 1) pour fixation sur barre de montage diamètre 12 mm
- 1) para fijación de barras de montaje de diametro 12 mm

TECHNISCHE DATEN (TYP.) TECHNICAL DATA (TYP.) DONNÉES TECHNIQUES (TYP.) DATOS TÉCNICOS (TYP.)															
D Gehäusematerial		GB Casing material		F Matériau de boîtier		E Materiale della Custodia		Anodised aluminium							
Gewicht 6 / 7		Weight 6 / 7		Poids 6 / 7		Peso 6 / 7		Approx. 210 g / 240 g							
D BESTIMMUNGSGEMÄSSE VERWENDUNG			GB INTENDED USE			F UTILISATION CONFORME			E USO DEBIDO						
Zur Montage für VISOR®			For mounting VISOR®			Pour le montage du VISOR®			Para montaje de VISOR®						
LIEFERUMFANG			COMPONENTS SUPPLIED			COMPOSANTS FOURNIS			VOLUMEN DE SUMINISTRO						
MG xx, Montageanleitung			MG xx, mounting instructions			MG xx, instructions de montage			MG xx, instrucciones de montaje						
			D BESCHREIBUNG			GB DESCRIPTION			F DESCRIPTION			E DESCRIPCIÓN			
6 MG 3A		543-11024		Montagegelenk mit 3 Achsen			Mounting hinge with 3 axes			Articulation de montage avec 3 axes			Articulación de montaje con 3 ejes		
7 MG 3A-MST12		543-11034		Montagegelenk mit 3 Achsen für Befestigung an 12 mm Montagestangen			Mounting hinge with 3 axes for fixing at mounting rods 12 mm			Articulation de montage avec 3 axes pour fixation sur barre de montage diamètre 12 mm			Articulación de montaje con 3 ejes para fijación de barras de montaje de diametro 12 mm		
MASSBILD DIMENSIONAL DRAWING PLAN COTES ESQUEMA DE DIMENSIONES															
6 MG 3A						7 MG 3A-MST12									

D HINWEIS	GB Note	F Note	E Nota	
Maximales Anzugsdrehmoment Schrauben M6	Maximum tightening torque screws M6	Couple de serrage maximal pour les vis M6	Par de apriete máximo para los tornillos M6	6 Nm

MONTAGE | ASSEMBLY | MONTAGE | MONTAJE

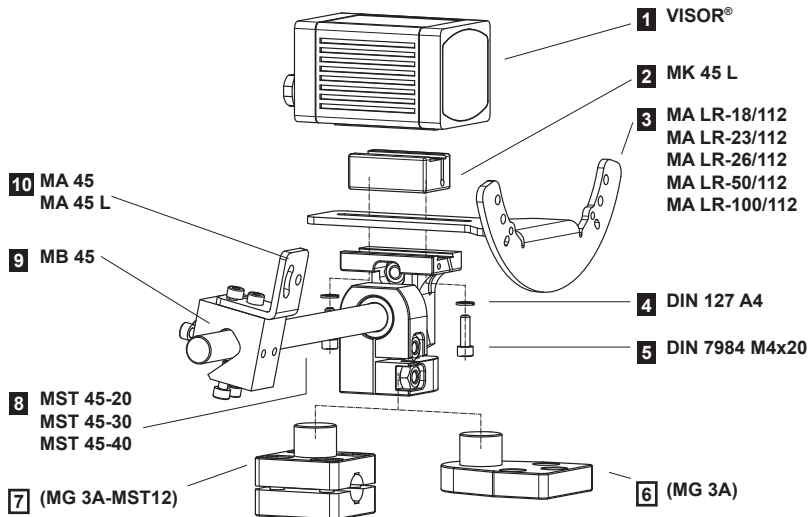

ZUBEHÖR | ACCESSORIES | ACCESSOIRES | ACCESORIOS

		D BESCHREIBUNG	GB DESCRIPTION	F DESCRIPTION	E DESCRIPCIÓN	
1	VISOR®	VISOR®	VISOR®	VISOR®	VISOR®	
2	MK 45 L	543-11021	Montageklammer lang	Mounting clamp long	Pince de montage, longue	Abrazadera de montaje, largo
			Haltewinkel für Beleuchtung	Angle bracket for lighting	Angle bracket for lighting	Ángulo de fijación iluminación
3	MA LR-18/112	543-11016	Ø 18 mm	Ø 18 mm	Ø 18 mm	Ø 18 mm
	MA LR-23/112	543-11019	Ø 23 mm	Ø 23 mm	Ø 23 mm	Ø 23 mm
	MA LR-26/112	543-11017	Ø 26 mm	Ø 26 mm	Ø 26 mm	Ø 26 mm
	MA LR-50/112	543-11018	Ø 50 mm	Ø 50 mm	Ø 50 mm	Ø 50 mm
	MA LR-100/112	543-11015	Ø 100 mm	Ø 100 mm	Ø 100 mm	Ø 100 mm
4	DIN 127 A4	Federscheibe	Spring disk	Disque de ressort	Arandela elástica	
5	DIN 7984 M4x20	Schraube	Screw	Vis	Tornillo	
		Montagestange	Mounting rod	Barre de montage	Barra de montaje	
8	MST 45-20	543-11005	200 mm	200 mm	200 mm	200 mm
	MST 45-30	543-11006	300 mm	300 mm	300 mm	300 mm
	MST 45-40	543-11007	400 mm	400 mm	400 mm	400 mm
9	MB 45	543-11002	Montageblock	Mounting block	Bloc de montage	Bloque de montaje
10	MA 45	543-11001	Montagewinkel	Mounting angle	Équerre de montage	Ángulo de montaje
	MA 45 L	543-11013	Montagewinkel lang	Mounting angle long	Équerre de montage, longue	Ángulo de montaje, largo